

**INDIVIDUAL  
CONSENT CALENDAR**

**BELVEDERE CITY COUNCIL  
FEBRUARY 11, 2019**

---

To: Mayor and City Council

From: Irene Borba, Director of Planning & Building

Subject: **Approve revocable license for private improvements in the City street right-of-way in front of 101 Bella Vista Avenue**

---

**Recommended Motion/Item Description**

1. That Mayor McCaskill and Council Members Campbell and Kemnitzer state for the record that their residences are within 500 feet of the subject property and therefore they must recuse themselves from this item. *The Political Reform Act provides that when three of the five Council Members have a conflict of interest, one of the three Council Member names may be chosen at random to participate and vote on the matter. At the meeting, the City Clerk will draw a random name of the Council Member to participate.* [The remaining recused Council Members need not leave the dais.]
2. That the City Council approve the revocable license agreement for 101 Bella Vista Avenue for improvements in the street right-of-way.

**Background and Findings**

***Proposed encroachment on City property – 101 Bella Vista Avenue– APN 060-171-14***

The attached license agreement requires the property owner to assume liability and maintenance responsibilities for:

French drain dissipator in the street right-of-way in front of 101 Bella Vista Avenue  
(Refer to attached draft Revocable License No. 2019.06 and associated exhibit.)

***Background of current application***

The subject property at 101 Bella Vista Avenue has submitted for a building permit to make required drainage improvements. A revocable license is required for the new storm drain outlet pipe and the dissipator that will encroach into the city right-of-way.

The encroachment for the drainage improvements are necessary and required to allow adequate drainage from the property to occur.

***Compliance with Administrative Policy Manual Section 272.05, Revocable Licenses***

In accordance with Section 272.05 of the City's Administrative Policy Manual (as revised May 14, 2018), a revocable license for private use of excess street right-of-way may be granted at the

discretion of the City Council when there is some benefit to the public, and provided that any proposed encroachment into the right-of-way complies with the design review requirements of Title 20 of the Belvedere Municipal Code. The policy lists several criteria to consider when determining whether to grant a revocable license for private use of excess right-of-way. The applicable policy is as follows:

- d. Where the public right-of-way will be used to construct retaining walls, drainage structures or other facilities that the City considers necessary to protect or maintain the public infrastructure;*
- 

As noted above, a revocable license is required for the new storm drain outlet pipe and the dissipator that will encroach into the City right-of-way. The encroachment for the drainage improvements are necessary and required to allow adequate drainage from the property to occur.

***Public Benefit***

The project benefits the public as it will allow for adequate and proper drainage from the property to occur, protecting the subject property, neighboring properties, and City property.

***Future improvements***

The license covers any future improvements within the revocable license area which receive staff or Planning Commission design review approval and which meet one or more of the criteria for approval of revocable license listed in the City's Administrative Policy Manual, Policy 272.05, as adopted by City Council resolution. Applications for substantial, potentially permanent and/or obstructive structures within the City right-of-way, which fall outside the criteria, will still be required to go to the City Council for consideration and approval/denial. Detailed records at City Hall, maintained in the Planning Department file for this address, will always be available to show exactly what structures have been approved within the license area. This will save considerable staff time that would be devoted to bringing a revised license and staff report to the City Council and in issuing, recording, and archiving a new license agreement.

**Recommended Action**

1. That Mayor McCaskill and Council Members Campbell and Kemnitzer state for the record that their residences are within 500 feet of the subject property and therefore they must recuse themselves from this item. *The Political Reform Act provides that when three of the five Council Members have a conflict of interest, one of the three Council Member names may be chosen at random to participate and vote on the matter. At the meeting, the City Clerk will draw a random name of the Council Member to participate.* [The remaining recused Council Members need not leave the dais.]
2. That the City Council approve the revocable license agreement for 101 Bella Vista Avenue for improvements in the street right-of-way.

**Attachments**

- Draft license agreement with attached exhibit.
- Photo of existing conditions.
- Elevations.

RECORDING REQUESTED BY:  
City Clerk, City of Belvedere  
RECORD WITHOUT FEE PER G.C. 27383

AND WHEN RECORDED MAIL TO:

City Clerk  
City of Belvedere  
450 San Rafael Avenue  
Belvedere, CA 94920-2336

**CITY OF BELVEDERE**

**REVOCABLE LICENSE NO. 2019.06**

ASSESSOR'S PARCEL NO.: **060-171-14**  
ADDRESS: **101 Bella Vista Avenue, Belvedere, California 94920**  
OWNER: **The Denniston Living Trust et al**  
DATE ISSUED: **February 11, 2019**

The City of Belvedere, California, a municipal corporation (hereinafter referred to as "City"), hereby authorizes and licenses the owner of the land described above and in Exhibit "A" (hereinafter referred to as "Licensee"), at its own cost and expense, to encroach upon the adjoining land owned by the City of Belvedere (hereinafter referred to as "Premises") for the following purpose: French drain dissipator.

The above-described improvements received City design review approval. This license shall cover any future improvements within the revocable license area which receive design review approval and which meet one or more of the criteria adopted by City Council resolution for the granting of revocable licenses. Any future revocable license application which does not meet the criteria must be approved by the City Council.

This revocable license is granted subject to the following terms and conditions:

1. Licensee shall save and hold harmless the City of Belvedere from any loss, damage, or injury of any kind or character whatsoever that may arise from anything done, or omitted to be done, by Licensee, its agents, employees or contractors in connection with or in any way related to the matters authorized by this License. Licensee agrees to hold City harmless and indemnify City (including, but not limited to, attorney fees, expert witness costs and court costs), without limitation, from and against any and all claims, injuries, damage, liability and/or cause of action which may ever arise as a result of injury and/or damage to property claimed to be the result of construction and/or failure to maintain said property or improvements by Licensee in, on, under, or above City property which is the subject of the revocable license granted Licensee by City.
2. To the extent this License authorizes the erection or installation of any building, fence, wall, or other structure or facility in or upon land owned by City, Licensee agrees to erect and install the same in accordance with plans and specifications approved by the Planning Commission of the City of Belvedere and further agrees to maintain the same at all times in good condition and repair, all at Licensee's sole cost and expense.
3. To the extent this License authorizes the erection or installation of any infrastructure improvements which are subject to the Americans With Disabilities Act ("the Act"), Licensee agrees to construct and maintain those improvements in full compliance with the requirements of the Act.
4. If Licensee shall fail to comply with the terms and conditions of this License, the City, at its option may immediately terminate and revoke this License by mailing or delivering written notice

- thereof to Licensee at the address hereinabove stated. Licensee shall not restrict access by the public and/or by adjacent property owners to the licensed area.
5. Licensee shall execute this License by: signing the License; making an acknowledgement of the License before a notary public or an officer specified by the State to take the acknowledgement of instruments of writing; and delivering the signed License and certificate of acknowledgement to the City. If Licensee shall fail to execute this License within thirty days of the date issued, the City may immediately terminate and revoke this License by mailing or delivering written notice thereof to Licensee at the address hereinabove stated.
  6. Anything herein to the contrary notwithstanding, this License shall be revocable at the pleasure of the City Council of the City of Belvedere. The election to revoke this License may be exercised at any time by mailing or delivering to Licensee at the address hereinabove stated a notice of revocation and termination. Within the time specified in said notice, Licensee shall, at its own cost and expense, remove from the Premises the encroachment and all structures and facilities placed thereon or therein by Licensee.
  7. That upon the failure of Licensee to comply with any of the agreements contained herein, City may declare said improvements to be a public nuisance, and may take such action as may be authorized by law to abate said nuisance. The City shall be entitled to recover from Licensee costs of suit and reasonable attorney's fees, to be determined by the court. The remedy of City as contained in this paragraph shall not be exclusive.
  8. The Licensee acknowledges that the property interest created hereunder by issuance of this license may be subject to possessory interest taxation and said Licensee in whom such possessory interest is vested recognizes and agrees that it/they shall be solely responsible for payment of all such taxes levied upon said possessory interest.
  9. The Licensee shall deliver this license to any successor in interest to the above-described land.
  10. The agreements contained herein are covenants and servitudes running with the land and shall be binding upon Licensee and its successors, assignors, executors, administrators, and personal representatives.
  11. The Licensee shall obtain an encroachment permit from the City prior to the commencement of any work on City property.
  12. Any previous revocable licenses issued to this property are now null and void.

Issued by direction of the City Council of the City of Belvedere pursuant to action taken at its meeting of February 11, 2019.

---

Craig Middleton, City Manager

The foregoing License is accepted and its terms and conditions are agreed to:

The Denniston Living Trust et al, Licensee

By: \_\_\_\_\_  
Derek C. Denniston, Co-Trustee

By: \_\_\_\_\_  
Christine N.B. Denniston, Co-Trustee

Revocable License Exhibit A  
LICENSE AREA SHOWN SHADED

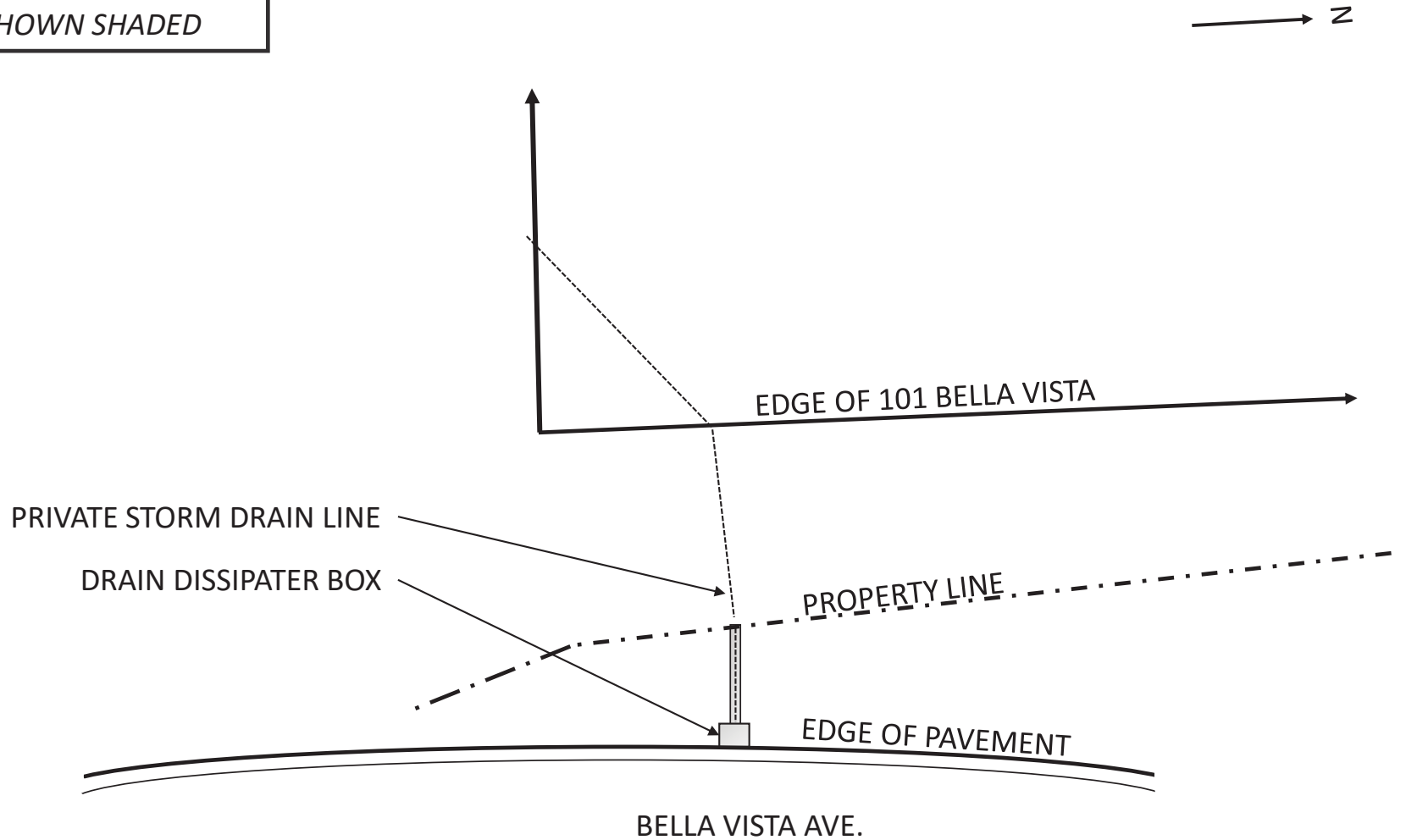

101 BELLA VISTA AVE., BELVEDERE, CA 94920 APN: 060-171-14

101 Bella Vista Ave.

Belvedere, California

Parcel # 060-171-14

Proposed location  
for drain dissipater  
in parking area



Per field review

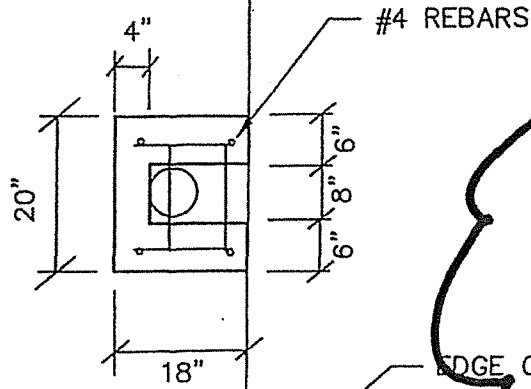

PLAN  
NO SCALE

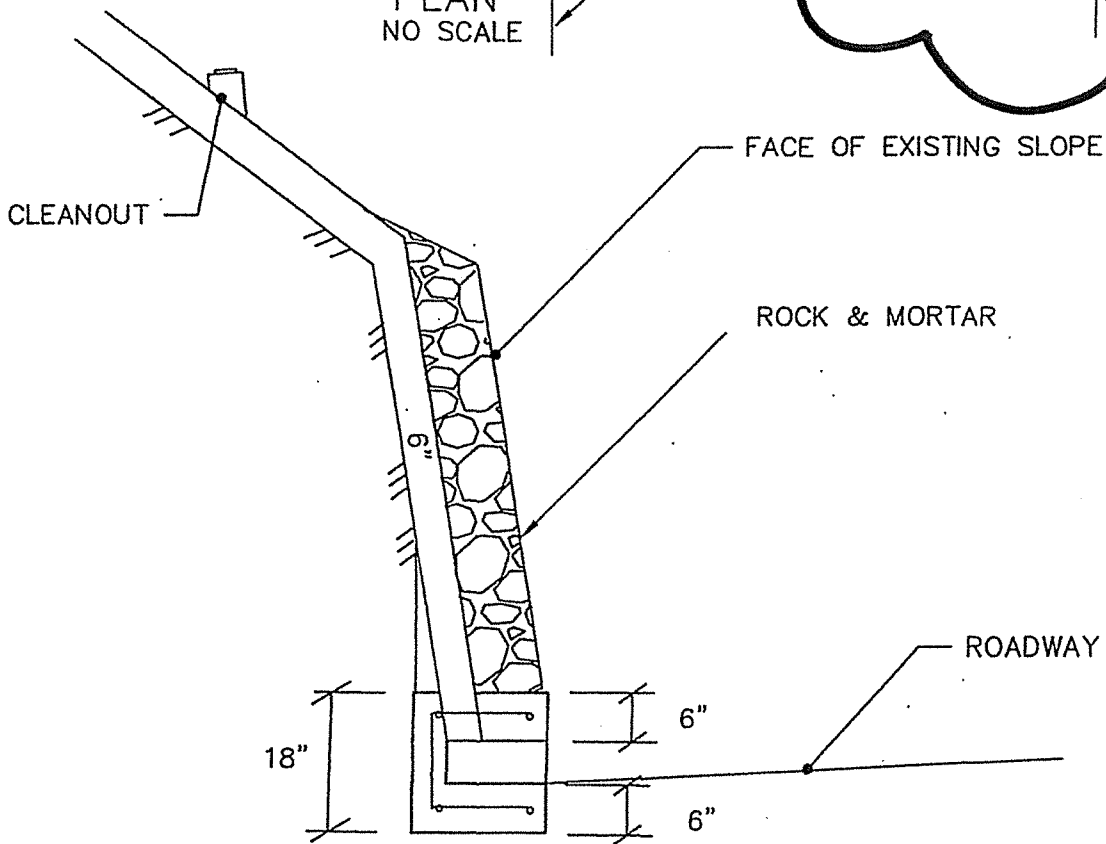
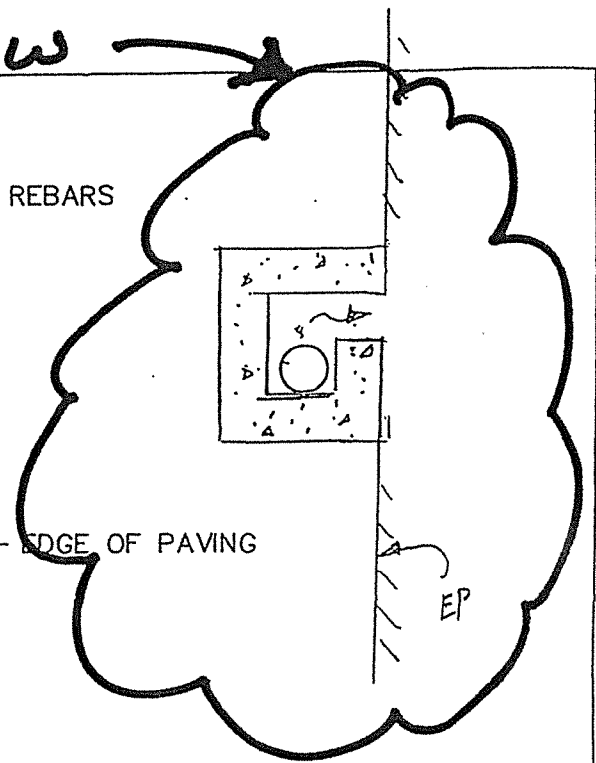

SECTION  
NO SCALE

BELVEDERE MARIN COUNTY CALIFORNIA		
DATE: 4/18/13	LAWRENCE P. DOYLE LAND SURVEYOR/CIVIL ENGINEER 100 HELENS LANE MILL VALLEY CA 94941 (415-388-9585)	DRAWN BY: SHEET 1 OF 1
		DRAWING NO.